



**HOTLINE<sup>®</sup>**  
**Blood and Fluid Warmer**

**REF** HL-90

**OPERATOR'S MANUAL**

PN 4534005-GB Rev. 007

**smiths medical**

**HOTLINE® Blood and Fluid Warmer**

Part Number: 4534005-GB Rev. 007 (2009-12)

This revision supercedes all previous revisions.

Every effort has been made to ensure that the information in this manual is accurate and details provided are correct at the time of printing. The company, however, reserves the right to improve the equipment shown. Mention of third-party products is for informational purposes only and constitutes neither an endorsement nor a recommendation. Smiths Medical ASD, Inc. (“Smiths Medical”) assumes no responsibility with regard to the performance or use of these products.

Smiths Medical and Level 1 design marks and Level 1 and HOTLINE are trademarks of the Smiths Medical family of companies. The symbol ® indicates the trademark is registered in the U.S. Patent and Trademark office and certain other countries.

All other names and marks mentioned are the trade names, trademarks, or service marks of the respective owners.

For further information, please call your local Smiths Medical distributor or Smiths Medical direct at 1-800-258-5361 or +1-781-878-8011.

©2009 Smiths Medical family of companies. All rights reserved.

# Contents

<b>1</b>	<b>About this Manual</b>	<b>1</b>
	Indications for Use	1
	Conventions Used in this Manual	1
<b>2</b>	<b>Description</b>	<b>2</b>
	Components	2
	HOTLINE® Fluid Warming Set	4
<b>3</b>	<b>Important Safety Information</b>	<b>5</b>
	Additional WARNINGS and CAUTIONS for Accessories	8
<b>4</b>	<b>Assembly Instructions</b>	<b>9</b>
	Step 1 - Unpack the HOTLINE® Warmer	9
	Step 2 - Clamp the HOTLINE® Warmer to the I.V. Pole	9
	Step 3 - Disinfect the Reservoir	10
	Step 4 - Fill the Reservoir With Recirculating Solution	11
	Step 5 - Perform the Electrical Safety Tests	11
<b>5</b>	<b>Principle of Operation</b>	<b>12</b>
	Infusate Delivery Temperatures	12
<b>6</b>	<b>Operation</b>	<b>13</b>
	<b>Controls and Displays</b>	<b>13</b>
	Display Panel	13
	Power and Alarm Test Panel	14
	Reservoir Level Display	14
	<b>Modes of Operation</b>	<b>15</b>
	OFF Mode	15
	ON/Operating Mode	15
	Check Disposables Mode	15
	Add Recirculating Solution Mode	16
	Over Temperature Alarm Mode	16
<b>7</b>	<b>Operating Instructions</b>	<b>17</b>
	Step 1 - Set Up the HOTLINE® Warmer	17
	Step 2 - Set Up the HOTLINE® Fluid Warming Set	17
	Step 3 - Connect the Intravenous Administration Set	19
	Step 4 - Using the HOTLINE® Warmer	19
	Step 5 - After Use	20
	Storage	20
<b>8</b>	<b>Troubleshooting</b>	<b>21</b>
<b>9</b>	<b>Testing</b>	<b>23</b>
	Alarm Signal Test	23
	Over Temperature Alarm Test	24
	Add Recirculating Solution Test	24
	Check Disposables Test	25
	Temperature Verification of the Recirculating Solution	25
	Periodic Electrical Testing	27
	Leakage Current	27

---

Ground Bond Test	27
<b>10 Maintenance</b>	<b>28</b>
<b>Maintenance Performed with Every Use</b>	<b>28</b>
Clean the Exterior	28
General Inspection	30
<b>Disinfect the Reservoir and Change the Recirculating Solution</b>	<b>30</b>
Disinfect the Reservoir	30
Add Recirculating Solution	31
<b>Maintenance Performed Every 30 Days</b>	<b>31</b>
Disinfect the Reservoir and Change Recirculating Solution for Distilled Water and 35% Isopropyl Alcohol Solution	31
Lubricate O-Ring Seals	32
<b>Maintenance Performed Every 12 Months</b>	<b>32</b>
Disinfect the Reservoir and Change Recirculating Solution for 0.3% Hydrogen Peroxide Solution	32
Replace O-Rings (O-Ring Kit: P/N 80-04-001)	32
<b>Testing HOTLINE® Warmer Operation</b>	<b>32</b>
Maintenance Log	33
<b>11 Limited Warranty</b>	<b>34</b>
<b>12 Service</b>	<b>36</b>
Non-Warranty Work	36
Additional Documentation	36
Disposal Information	37
<b>Service Contacts</b>	<b>37</b>
USA/Canada	37
European Representative	37
Australian Representative	37
<b>13 Specifications and Accessories</b>	<b>38</b>
System Specifications	38
Electromagnetic Compliance	39
Electromagnetic Environmental Recommendations	40
Accessories	40
<b>14 Symbols</b>	<b>41</b>

## SECTION 1

# About this Manual

This operator's manual describes the assembly, use, and maintenance of the HOTLINE® Blood and Fluid Warmer. This manual is intended for use by individuals trained in the healthcare and biomedical professions.

**WARNING:** These instructions contain important information for safe use of the product. Read the entire contents of this operator's manual, including Warnings and Cautions, before using this product. Failure to properly follow warnings, cautions, and instructions could result in death or serious injury to the patient.

## Indications for Use

The HOTLINE® Blood and Fluid Warmer is designed for use with the HOTLINE® Fluid Warming Set to warm blood and intravenous (I.V.) fluids and deliver them to the patient's intravenous access site at normothermic temperatures under gravity flow conditions. The HOTLINE® Warmer is intended for use by trained medical personnel to provide routine flow of warmed I.V. fluid.

## Conventions Used in this Manual

- The HOTLINE® Blood and Fluid Warmer will be referred to as the HOTLINE® Warmer.
- The L Series Fluid Warming Sets (L-70, L-70NI, L-80) will be referred to as the HOTLINE® Fluid Warming Set or Disposable Set.

Convention	Description
<b>CONTRAINDICATION</b>	A Contraindication statement alerts the user to conditions when the device should not be used.
<b>CAUTION</b>	A Caution statement alerts the user to conditions that may cause malfunction, failure, or damage to the device.
<b>WARNING</b>	A Warning statement alerts the user to conditions that may cause death or serious injury to the patient or user.

## SECTION 2

# Description

The HOTLINE® Warmer delivers blood and intravenous fluid at normothermic temperatures by surrounding the sterile intravenous line with a layer of warmed recirculating solution. An onboard recirculating solution supply is heated to  $41.5^{\circ}\text{C} \pm 0.5$  and circulated through the outer lumen of the HOTLINE® Fluid Warming Set, which surrounds the intravenous line.

The HOTLINE® Warmer employs a safe, recirculating solution heating system, inherently free of “hot spots,” to actively warm the patient line. Electronic circuitry continuously monitors the recirculating solution temperature. The primary temperature control circuit limits the recirculating solution to  $42^{\circ}\text{C}$  maximum. In the unlikely event of a malfunction of this circuit, a second “watchdog” circuit will visually and audibly alarm and stop the recirculating solution pump if the temperature reaches  $43.1^{\circ}\text{C}$ . Fluid in the HOTLINE® Fluid Warming Set is never exposed to any damaging or dangerous temperatures while the HOTLINE® Warmer is operating.

The recirculating solution temperature and visual alarms are indicated on the Display Panel on the front of the HOTLINE® Warmer. A green Operating light illuminates on this panel when the HOTLINE® Warmer is set up and operating correctly.

## Components

The HOTLINE® components are called-out in the following series of figures.

### Front View

- 1** Socket for HOTLINE® Fluid Warming Set with the reflux plug in place
- 2** Display Panel

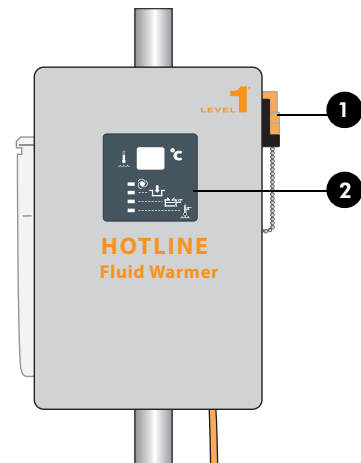

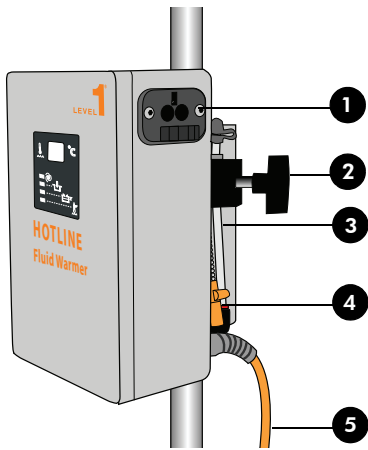

**Right Side View**

- 1 Socket with the reflux plug removed
- 2 Clamp for I.V. pole
- 3 Drain tube in tube holder
- 4 Reflux plug
- 5 Power cord

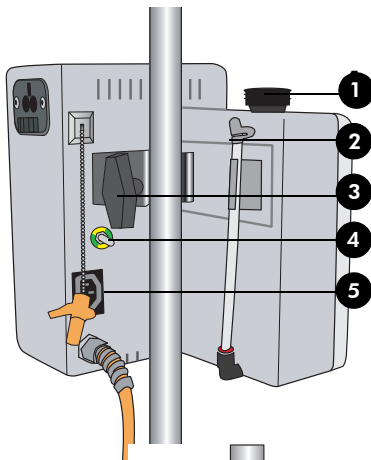

**Rear View**

- 1 Fill-port plug
- 2 Drain tube in tube holder
- 3 Clamp for I.V. pole
- 4 Protective earth terminal
- 5 Auxiliary electrical outlet (uncovered)

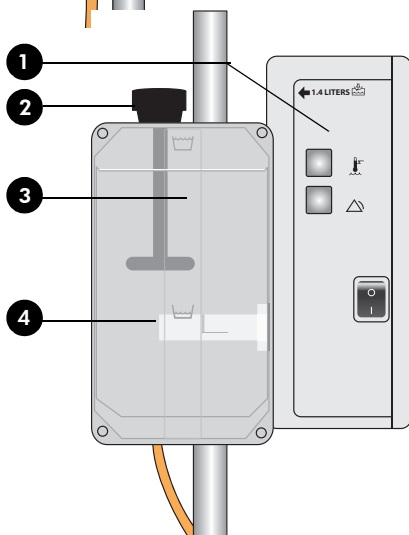

**Left Side View**

- 1 Power and Alarm Test Panel
- 2 Fill-port plug
- 3 Reservoir, contains recirculating solution
- 4 Float switch (inside reservoir)

## **HOTLINE® Fluid Warming Set**

HOTLINE® Fluid Warming Sets (L-70, L-70NI, L-80) are individually packed, single-use disposables with a Sterile Fluid Path. The priming volume is 20 ml for the L-70 and L-70NI, and 21 ml for the L-80. The HOTLINE® Fluid Warming Set has a Twin-Tube Connector that plugs into the socket on the right side of the HOTLINE® Warmer. This is the only connection necessary to provide the warming function. The HOTLINE® Fluid Warming Set is easily unplugged from the HOTLINE® Warmer and discarded.

## SECTION 3

# Important Safety Information

This section covers information for prescribers and guidelines for safe use of the HOTLINE® Warmer.

---

## CONTRAINDICATIONS

- Not for use in warming platelets, cryo-precipitates, or granulocyte suspensions.

---

## WARNINGS

Death or serious injury may occur to the patient or user if these warnings are not followed.

- These instructions contain important information for safe use of the product. Read the entire contents of this operator's manual, including Warnings and Cautions, before using this product. Failure to properly follow warnings, cautions, and instructions could result in death or serious injury to the patient.
- The HOTLINE® Fluid Warming Set, L-10, PC-8, and YC-8 are single-use devices and are not intended for re-sterilization.
- Do not use HOTLINE® Fluid Warming Set, L-10, PC-8, and YC-8 if the caps are not securely in place, else the I.V. flow path may not be sterile.
- The HOTLINE® Warmer is for use only with Smiths Medical supplied or approved parts, accessories, and Disposable Sets. The device may not function as intended with the use of unapproved parts, accessories, or Disposable Sets.
- Blood and blood products could contain pathogenic organisms. Failure to follow institutional policy and procedures for biomedical-hazardous materials could lead to exposure to harmful pathogens.
- Set-up, priming, and use require aseptic technique as per applicable institutional policies and procedures.

*Continued*

---

*Continued from previous page*

---

### **WARNINGS**

- Prime the recirculating solution path before connecting to the intravenous extension set. This is to confirm that there is not a breach between the recirculating solution path and intravenous path. If fluid exits the patient end of the **HOTLINE® Fluid Warming Set** before connecting to the intravenous administration set, remove and replace **HOTLINE® Fluid Warming Set**.
- Remove all air from the **HOTLINE® Fluid Warming Set, L-10, PC-8, and YC-8** before connecting to the patient. Failure to do so may result in introduction of air to the patient.
- Not for use with pressure devices generating over 300 mmHg. Pressure greater than 300 mmHg may compromise the integrity of the **HOTLINE® Fluid Warming Set**.
- To prevent a breach between the recirculating solution path and intravenous path, do not use needles greater than 38 mm (1.5") in length when accessing the injection port. If there is a breach between the recirculating solution path and intravenous path, patient illness may occur because of the **HOTLINE® Warmer's** recirculating solution entering the patient's bloodstream.
- Do not stick the **HOTLINE® Fluid Warming Set** with needles, as this will breach the I.V. path and compromise the integrity of the patient intravenous line. If a Disposable Set with a breached recirculating solution path/intravenous path is used, then patient illness may occur because of the **HOTLINE® Warmer's** recirculating solution entering the patient's bloodstream.
- Activation of the Over Temperature warning signal indicates that warming has stopped and immediate operator intervention is required to clear the over temperature condition or to remove the device from service.
- If any visual indicator does not illuminate or the audible signal does not sound, do not use the **HOTLINE® Warmer**. Remove the device from service immediately.
- Do not operate the **HOTLINE® Warmer** in the presence of a flammable anesthetic mixture with air, oxygen, or nitrous oxide. The risk of explosion exists if the **HOTLINE® Warmer** is operated in a potentially explosive environment.

*Continued*

*Continued from previous page*

---

### **WARNINGS**

- Do not use the **HOTLINE®** Warmer in high-energy fields such as: MRI, X-RAY, portable and mobile RF communications equipment, and other such devices. The **HOTLINE®** Warmer may act as a projectile in a strong magnetic field, cause image artifacts, or not function as intended.
- Exposed conductor on **MAINS** power cord can cause an electrocution hazard. Remove device from service if the **MAINS** power cord has exposed wires.
- Grounding reliability can only be achieved when the **MAINS** power cord is connected to a properly grounded receptacle. Risk of electrical shock exists if the equipment is not connected to a properly grounded receptacle.
- Do not mount the **HOTLINE®** Warmer more than 107cm (42") above the floor. For convenience, 107cm (42") is indicated on the **HOTLINE®** Warmer power cord by a black mark. Mounting the **HOTLINE®** Warmer above 107cm (42") may result in instability of the pole and tipping.
- Ensure that the **HOTLINE®** Warmer clamp is screwed tightly onto the I.V. pole. Failure to securely mount the **HOTLINE®** Warmer onto the I.V. pole may cause the **HOTLINE®** Warmer to slide down the I.V. pole.
- Do not use the **HOTLINE®** Warmer if equipment or Disposable Set malfunction is evident.
- No user-serviceable parts. All service must be performed by Smiths Medical or competent personnel.

---

### **CAUTIONS**

Malfunction, failure, or damage to the device may occur if these cautions are not followed.

- Federal (U.S.A.) law restricts this device to sale by or on the order of a physician.
- Do not autoclave or immerse any part of the **HOTLINE®** Warmer in liquids, which may cause damage and improper functioning.

*Continued*

---

*Continued from previous page*

---

### **CAUTIONS**

- Never use organic solvents (e.g., acetone), strong acids, or bases to clean any portion of the **HOTLINE®** Warmer.
- Do not place the **HOTLINE®** Warmer directly under a faucet or use a faucet sprayer to rinse. Never spray cleaning or other fluids into openings on the **HOTLINE®** Warmer or into the external connectors.
- This device is cooled by convection. Be sure the air vents on the bottom and the back of the device are kept clear.
- Do not fill the **HOTLINE®** Warmer reservoir with a **HOTLINE®** Fluid Warming Set in place. Failure to remove the **HOTLINE®** Fluid Warming Set before the fill procedure may result in an air lock in the **HOTLINE®** Warmer.
- Medical devices require specific material characteristics to perform as intended. These characteristics have been verified for single use only. Any attempt to re-process the device for subsequent re-use may adversely affect the integrity of the device or lead to deterioration in performance.

---

### **Additional WARNINGS and CAUTIONS for Accessories**

#### **WARNINGS for the L-10 Gas Vent and L-80 Fluid Warming Set**

- Do not tape over vents, else air will not be vented.
- Not for use with volumetric infusion pumps, hand pumps, or syringes. These may compromise the integrity of the L-10 Gas Vent or **HOTLINE®** Fluid Warming Set.
- When the L-10 Gas Vent is in use, it should be placed at or below the heart level. Do not raise the gas vent above the patient's heart level. If the gas vent is raised above heart level, air may be entrained into the infusion line, possibly causing air embolism, resulting in serious injury or death.

#### **CAUTIONS for the L-10 Gas Vent and L-80 Fluid Warming Set**

- This product contains natural rubber latex, which may cause allergic reactions.
-

## SECTION 4

# Assembly Instructions

Read through the instructions completely prior to setting up the HOTLINE® Warmer.

## Step 1 - Unpack the HOTLINE® Warmer

- 1 Open the shipping carton and remove the HOTLINE® Warmer.
- 2 Check the contents of the package to verify the following components are present:
  - HOTLINE® Warmer
  - Operator's Manual
  - HOTLINE® Inspection/Test Form
- 3 Examine the HOTLINE® Warmer for damage. If any components appear damaged, do not use the HOTLINE® Warmer. Contact Smiths Medical for a replacement.

**Note:** After unpacking the HOTLINE® Warmer, recycle packaging material according to hospital policy for recyclable materials.

## Step 2 - Clamp the HOTLINE® Warmer to the I.V. Pole

---

### WARNINGS

- Ensure that the HOTLINE® Warmer pole clamp is screwed tightly onto the I.V. pole. Failure to securely mount the HOTLINE® Warmer onto the I.V. pole may cause the HOTLINE® Warmer to slide down the pole and may injure the patient or user.
- Do not mount the HOTLINE® Warmer more than 107cm (42") above the floor. For convenience, 107cm (42") is indicated on the HOTLINE® Warmer line cord by a black mark. Mounting the HOTLINE® Warmer above 107cm (42") may result in instability of the pole and tipping that may injure the patient or user.

---

### CAUTIONS

- This device is cooled by convection. Be sure the air vents on the bottom and the back of the device are kept clear.
-

- 1 Slide the clamp (a) on the HOTLINE® Warmer over the I.V. pole (b) and tighten the clamp screw (c) firmly.
- 2 Check the tightness of the HOTLINE® Warmer to ensure it is securely clamped to the pole.

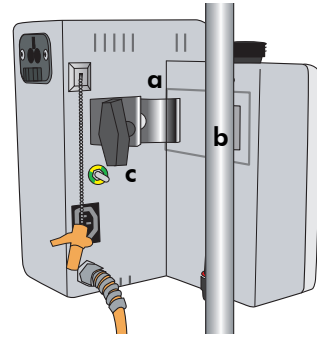

### Step 3 - Disinfect the Reservoir

- 1 Prepare a 0.3% hydrogen peroxide solution by mixing 140 ml of 3% hydrogen peroxide solution and 1,260 ml of distilled water.
- 2 Remove the reflux plug from the socket if required, and then remove the fill-port plug (d) and fill the reservoir with 1.4 liters of 0.3% hydrogen peroxide solution.
- 3 Replace the fill-port plug (d).
- 4 Insert a HOTLINE® Fluid Warming Set (e) (L-70, L-70 NI, L-80) into the socket.
- 5 Plug the HOTLINE® Warmer into properly grounded power outlet.
- 6 Turn the HOTLINE® Warmer ON and let the solution circulate for a 30-minute disinfection period.
- 7 Turn the HOTLINE® Warmer OFF.

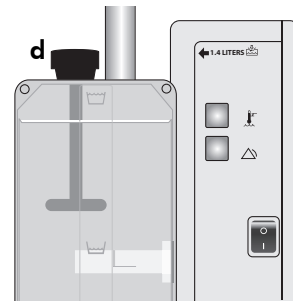

- 8 Invert the drain tube (f) and place a container under the end of the tube. Remove the end cap (g) and drain the recirculating solution into the container.
- 9 When all the recirculating solution has drained from the reservoir, replace the end cap and insert the drain tube back in the holder.
- 10 Remove the HOTLINE® Fluid Warming Set and discard according to established hospital procedures.

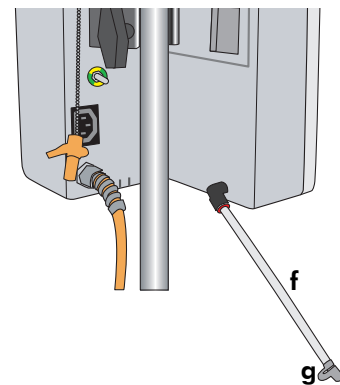
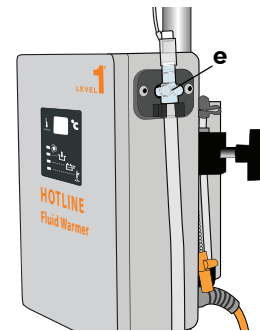

## Step 4 - Fill the Reservoir With Recirculating Solution

### WARNINGS

- Do not fill the HOTLINE® Warmer reservoir with a HOTLINE® Fluid Warming Set in place. Failure to remove the HOTLINE® Fluid Warming Set before the fill procedure may result in an air lock in the HOTLINE® Warmer.

### Recirculating Solution Protocols

Use one of the following solutions for the reservoir.

Recirculating Solution	Preparation	Maintenance
0.3% Hydrogen Peroxide Solution	Mix 140 ml of 3% hydrogen peroxide with 1,260 ml of distilled water.	Replace solution and disinfect reservoir every 12 months.
Distilled Water	Use distilled water.	Replace solution and disinfect reservoir every 30 days.
35% Isopropyl Alcohol Solution	Mix 700 ml of 70% isopropyl alcohol with 700 ml of distilled water.	Replace solution and disinfect reservoir every 30 days.

**Note:** Use distilled water only, not tap water. Failure to do so may cause build-up of mineral deposits in the recirculating solution path, which may impair heater performance.

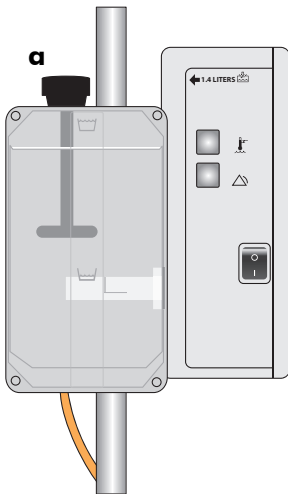

- 1 Prepare the recirculating solution.
- 2 Remove the fill-port plug (a).
- 3 Fill the reservoir with 1.4 liters of recirculating solution.
- 4 Replace the fill-port plug.

## Step 5 - Perform the Electrical Safety Tests

Perform all applicable electrical safety tests as required per institutional procedure. Refer to Section 9, *Testing*, for more information about electrical safety testing.

## SECTION 5

# Principle of Operation

HOTLINE® Warmer delivers blood and intravenous fluid at normothermic temperatures under routine, gravity flow rates. Conventional fluid warming systems suffer from cool-down between the warmer and the patient connection. HOTLINE® Warmer overcomes this problem by providing active warming of the patient line all the way to the patient connection.

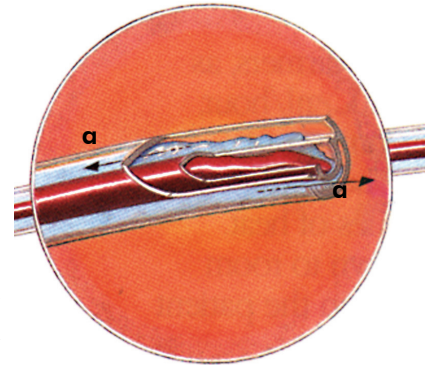

Active warming is achieved by surrounding the sterile intravenous line with a layer of precisely controlled warm recirculating solution (a), thereby protecting the patient line against exposure to cold and eliminating patient line cool-down.

The unique design of the HOTLINE® Fluid Warming Set allows blood and intravenous fluid to be delivered to the patient at normothermic temperature at gravity flow rates to 50-5,000 ml/hr.

## Infusate Delivery Temperatures

The following table shows the typical infusate delivery temperatures at the patient end of an L-70 HOTLINE® Fluid Warming Set.

**Note:** The setpoint temperature of the recirculating solution is 41.9°C.

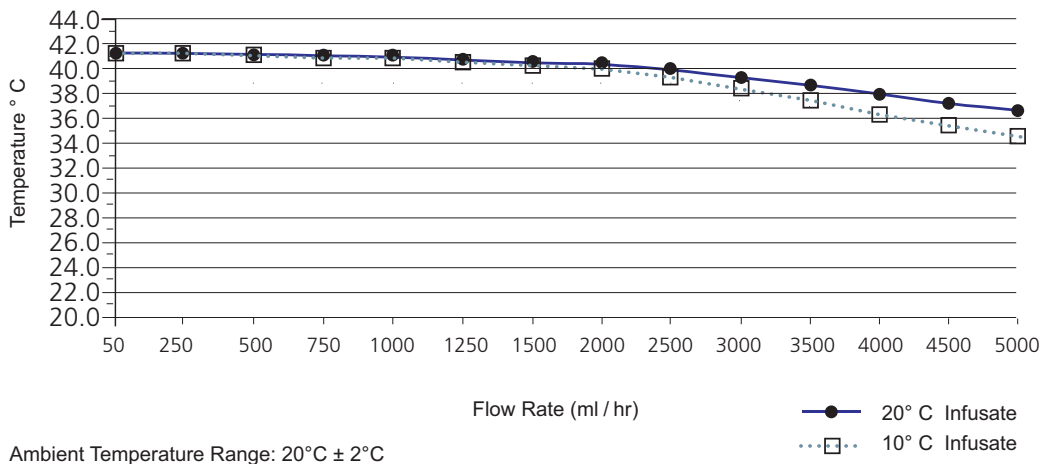

## SECTION 6

# Operation

This section describes the controls and displays that monitor and control the HOTLINE® Warmer, and the modes of operation.

## Controls and Displays

- Display Panel
- Power and Alarm Test Buttons
- Reservoir Level Display

### Display Panel

The Display Panel is located on the front of the HOTLINE® Warmer and provides continuous information about the operation of the HOTLINE® Warmer. A liquid crystal display (LCD) indicates recirculating solution temperature. Just below the LCD, four light-emitting diodes (LEDs) indicate operation modes for the HOTLINE® Warmer.

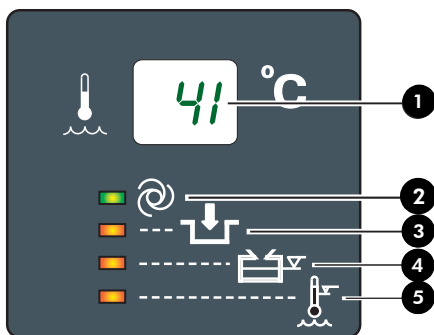

- 1 Recirculating Solution Temperature** - The temperature is displayed in degrees Celsius.
- 2 ON/Operation** - The green LED illuminates when the power is turned on and the HOTLINE® Fluid Warming set is properly installed.
- 3 Check Disposables** - The red LED illuminates and an audible attention signal beeps when the HOTLINE® Fluid Warming Set is not properly installed.
- 4 Add Recirculating Solution** - The red LED illuminates and an audible attention signal beeps when the level in the reservoir is low and additional recirculating solution must be added.
- 5 Over Temperature** - The red LED illuminates and an audible warning signal beeps when the recirculating solution is over the acceptable temperature for safe use.

### Power and Alarm Test Panel

The Power and Alarm Test Panel is located on the left side of the HOTLINE® Warmer next to the reservoir. This panel contains two pressure-sensitive buttons that are activated when pressed, and the ON/OFF switch.

- 1 Over Temperature Alarm Test Button** - The Over Temperature Alarm Test is used to confirm the proper operation of the Over Temperature circuitry.
- 2 Alarm Test Button** - The Alarm Signal Test is used to confirm proper operation of the visual and audible alarms.
- 3 Power ON/OFF Switch** - The black switch toggles to turn power ON and OFF.

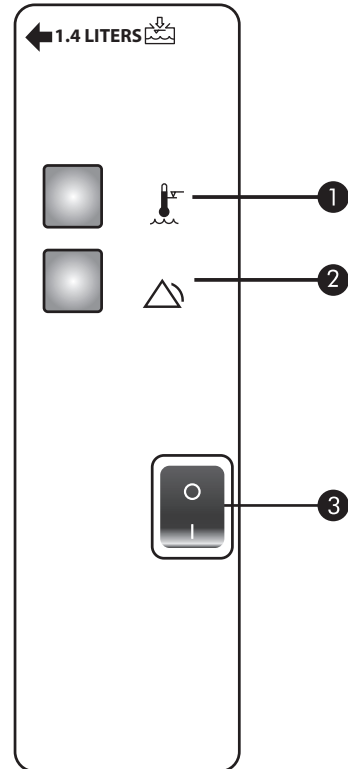

### Reservoir Level Display

The reservoir for the recirculating solution is located on the left side of the HOTLINE® Warmer, next to the Power and Alarm Test Panel. The level of the recirculating solution is visible in the reservoir. Two symbols indicate the maximum (a) and minimum (b) solution level requirements.

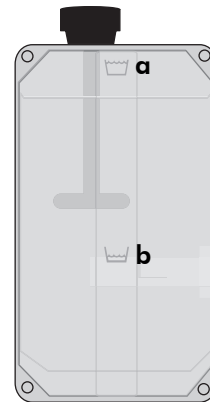

## Modes of Operation

The HOTLINE® Warmer operation is defined in the following modes:

- OFF Mode
- ON/Operating Mode
- Check Disposables Mode
- Add Recirculating Solution Mode
- Over Temperature Alarm Mode

The description of each mode includes a definition of the mode, activation and/or monitoring of the mode, mode characteristics, and method to clear the mode state.

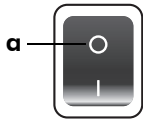

### OFF Mode

The power switch is in the OFF position (**a**) and the HOTLINE® Warmer is turned off.

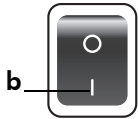

### ON/Operating Mode

The power switch is in the ON position (**b**) and the HOTLINE® Fluid Warming Set has been properly installed.



### Mode Characteristics

- The green Operating LED (**c**) illuminates.
- The reservoir temperature display will begin to increase.
- The recirculating solution path in the HOTLINE® Fluid Warming Set will automatically prime.

### Check Disposables Mode

The Check Disposables mode indicates a missing or improperly installed HOTLINE® Fluid Warming Set.



### Mode characteristics

- The green Operating LED on the Display Panel turns off.
- The red Check Disposables LED (**d**) on the Display Panel illuminates.
- The audible alarm sounds and repeats approximately every two seconds.
- The recirculating solution stops circulating.

To clear this mode, check that the Twin-Tube Connector on the HOTLINE® Fluid Warming Set is firmly inserted in the socket.

### Add Recirculating Solution Mode

The Add Recirculating Solution mode indicates that the solution level in the reservoir is below its minimum level.

#### Mode characteristics

- The green Operating LED on the Display Panel turns off.
- The red Add Solution LED (**a**) on the Display Panel illuminates.
- The audible alarm sounds and repeats approximately every two seconds.
- The recirculating solution stops circulating.



To clear this mode, add recirculating solution to the reservoir.

### Over Temperature Alarm Mode

The Over Temperature Alarm mode indicates that the temperature of the recirculating solution is at or above 43.1°C.

#### Mode characteristics

- The green Operating LED on the Display Panel turns off.
- The red Over Temperature LED (**b**) on the Display Panel illuminates.
- The audible alarm sounds and repeats approximately every two seconds.
- The recirculating solution stops circulating.

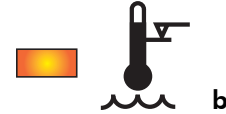

For instructions to clear this mode, see Section 8, *Troubleshooting*.

## SECTION 7

# Operating Instructions

The Operating Instructions are grouped into five segments. Read through each segment BEFORE performing a procedure.

## WARNINGS

- Set-up, priming, and use require aseptic technique as per applicable institutional policies and procedures. Death or serious injury may occur to the patient or user if this warning is not followed.
- Grounding reliability can only be achieved when MAINS power cords are connected to a properly grounded receptacle. Risk of electrical shock exists if the equipment is not connected to a properly grounded receptacle.
- Do not fill the HOTLINE® reservoir with a HOTLINE® Fluid Warming Set in place. Failure to remove the HOTLINE® Fluid Warming Set before the fill procedure may result in an air lock in the HOTLINE® Warmer.

## Step 1 - Set Up the HOTLINE® Warmer



- 1 Check that the level is above the minimum level mark (a) on the reservoir. Add recirculating solution to the reservoir through the fill-port if required.
- 2 Check the condition of the HOTLINE® Warmer with a visual inspection before using. Remove from service any HOTLINE® Warmer that shows physical damage.
- 3 Plug the HOTLINE® Warmer into properly grounded power outlet.

## Step 2 - Set Up the HOTLINE® Fluid Warming Set

## WARNINGS

- The HOTLINE® Fluid Warming Set is a single-use device and is not intended for re-sterilization. Death or serious injury may occur to the patient or user if this warning is not followed.

*Continued*

*Continued from previous page*

### WARNINGS

- Do not use HOTLINE® Fluid Warming Set, L-10, PC-8, and YC-8 if the caps are not securely in place, else flow path may not be sterile and may cause death or serious injury.
- Prime the recirculating solution path before connecting to the intravenous extension set. This is to confirm that there is not a breach between the recirculating solution path and intravenous path. If fluid exits the patient end of the HOTLINE® Fluid Warming Set before connecting to the intravenous extension set, remove and replace HOTLINE® Fluid Warming Set. Death or serious injury may occur to the patient or user if this warning is not followed.

To set up the HOTLINE® Fluid Warming Set, you will need the following:

- HOTLINE® Warmer
  - Intravenous administration set
  - Intravenous fluid or blood
  - Extension Set, 20cm (8") or less in length (optional)
- 1** Remove the reflux plug (if present) from the socket on the right side of the HOTLINE® Warmer.
  - 2** Plug the Twin-Tube Connector on the HOTLINE® Fluid Warming Set (**a**) into the socket.
  - 3** Turn ON the power switch.
    - The green Operating LED on the Display Panel illuminates.
    - The recirculating solution temperature display will begin to increase.
    - The recirculating solution path in the HOTLINE® Fluid Warming Set will automatically prime.
  - 4** Remove the end cap and inspect the patient end of the HOTLINE® Fluid Warming Set for leaks to confirm the integrity of the intravenous pathway.

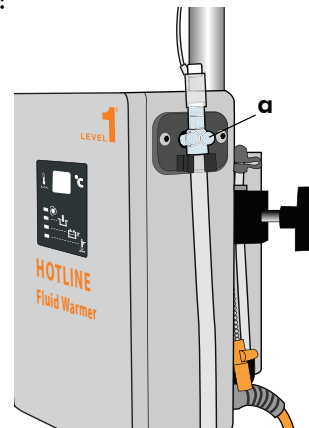

### Step 3 - Connect the Intravenous Administration Set

#### WARNINGS

- Remove all air from the HOTLINE® Fluid Warming Set, L-10, PC-8, and YC-8 before connecting to the patient. Failure to do so may result in introduction of air to the patient, which may contribute to serious patient injury or death.
- To prevent a breach between the recirculating solution path and intravenous path, do not use needles greater than 38 mm (1.5") in length when accessing the injection port. If there is a breach between the recirculating solution path and intravenous path, patient illness may occur because of the HOTLINE® Warmer's recirculating solution entering the patient's bloodstream.
- Do not stick the HOTLINE® Fluid Warming Set with needles, as this will breach the I.V. path and compromise the integrity of the patient intravenous line. If a Disposable Set with a breached recirculating solution path/intravenous path is used, then patient illness may occur because of the HOTLINE® Warmer's recirculating solution entering the patient's blood stream.

- 1 Connect the I.V. fluid and the intravenous administration set to the HOTLINE® Fluid Warming Set.
- 2 Fully prime the intravenous administration set, the HOTLINE® Fluid Warming Set, and patient extension set (if used).
- 3 Connect the distal end of the HOTLINE® Fluid Warming Set to the patient's intravenous access site without entrapping air.

### Step 4 - Using the HOTLINE® Warmer

#### WARNINGS

- Activation of the Over Temperature warning signal indicates that warming has stopped and immediate operator intervention is required to clear the over temperature condition or to remove the device from service. Death or serious injury may occur to the patient or user if this warning is not followed.
- If any visual indicator does not illuminate or the audible signal does not sound, do not use the HOTLINE® Warmer. Remove the device from service immediately. Death or serious injury may occur to the patient or user if this warning is not followed.

*Continued*

*Continued from previous page*

### WARNINGS

- Not for use with pressure devices generating over 300 mmHg. Pressure greater than 300 mmHg may compromise the integrity of the HOTLINE® Fluid Warming Set.

- 1 Wait until the recirculating solution temperature display reaches 41°C, which indicates the HOTLINE® Warmer is ready for use.
- 2 Adjust the rate of I.V. flow using the clamp on the intravenous administration set.

**Note:** Do not kink the Disposable Set. Do not restrict the circulation of the solution through the tubing.

### Step 5 - After Use

### WARNINGS

- Blood and blood products could contain pathogenic organisms. Failure to follow institutional policy and procedures for biomedical-hazardous materials could lead to exposure to harmful pathogens.

- 1 Turn OFF the power switch.
- 2 Remove the HOTLINE® Fluid Warming Set, and insert the reflux plug (a) into the socket.
- 3 After use, handle and dispose of the HOTLINE® Fluid Warming Set in a safe manner according to local guidelines for disposal of contaminated medical waste.
- 4 Wipe down the external surfaces of the HOTLINE® Warmer with mild liquid detergent soap and warm tap water mixture and a soft cloth or sponge. See Section 10, *Maintenance*, for more details about cleaning and external disinfection.

### Storage

Store the HOTLINE® Warmer in a cool, dry place. Do not expose to extreme temperatures. See Section 13, *Specifications*, for more details.

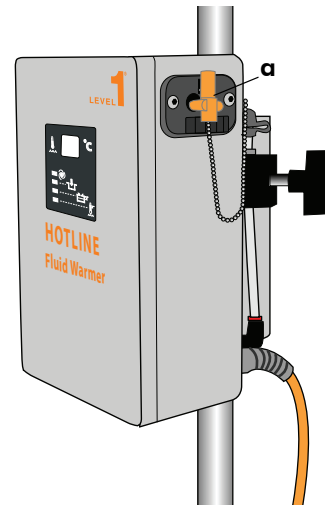

## SECTION 8

# Troubleshooting

Only competent personnel should perform any routine maintenance and repairs to the HOTLINE® Warmer.

Problem	Check the following
No power	<ol style="list-style-type: none"> <li>1 Confirm that the HOTLINE® Warmer is plugged in properly.</li> <li>2 Confirm that the power switch is in the ON position. <b>Note:</b> If the HOTLINE® Warmer is plugged in and the power switch is turned ON, the green or red LED will illuminate.</li> </ol>
Check Disposables alarm	<p>Confirm that the HOTLINE® Fluid Warming Set is properly installed.</p> <ol style="list-style-type: none"> <li>1 Push the Twin-Tube Connector firmly into the socket on the right side of the HOTLINE® Warmer. <b>Note:</b> Turn OFF the power switch before replacing the HOTLINE® Fluid Warming Set.</li> <li>2 If the alarm is not cleared, replace the HOTLINE® Fluid Warming Set. Turn ON the power switch and verify that the alarm has cleared.</li> <li>3 If the alarm is not cleared, remove the HOTLINE® Warmer from service.</li> </ol>
Add Recirculating Solution alarm	<p>Check the level in the reservoir</p> <ul style="list-style-type: none"> <li>• Turn OFF the power switch, remove the HOTLINE® Fluid Warming Set if installed, and add recirculating solution to the maximum level.</li> </ul>
Over Temperature alarm	<ol style="list-style-type: none"> <li>1 Check the HOTLINE® Fluid Warming Set for kinks or other restrictions.</li> <li>2 Check for air lock: <ol style="list-style-type: none"> <li>a Turn the power switch OFF, remove the HOTLINE® Fluid Warming Set, and gently shake HOTLINE® Warmer to dislodge air.</li> <li>b Plug in the HOTLINE® Fluid Warming Set and turn power switch ON.</li> <li>c If the alarm is not cleared, remove the HOTLINE® Warmer from service and return it for repair or replacement.</li> </ol> </li> </ol>

Problem	Check the following
Hot cabinet	<p>Check for blocked air vents on the bottom or the back of the HOTLINE® Warmer.</p> <p><b>Note:</b> Room temperature above 42°C may cause the HOTLINE® Warmer to shut down and the Over Temperature alarm to activate. In this situation, turn the power switch OFF and allow the HOTLINE® Warmer to cool down before returning it to service.</p>
Difficult to install the HOTLINE® Fluid Warming Set	Lubricate O-rings in the socket. Refer to Section 10, <i>Maintenance</i> , for the procedure.
Recirculating solution leaks at the socket where the HOTLINE® Fluid Warming Set plugs into the HOTLINE® Warmer	Replace O-rings. Use the O-ring Replacement Kit: P/N 80-04-001. Refer to Section 10, <i>Maintenance</i> , for the procedure.
Electrical interference - receiving or transmitting	<ol style="list-style-type: none"> <li>1 Move the HOTLINE® Warmer away from the device in question.</li> <li>2 Plug the HOTLINE® Warmer into a separate electrical circuit. <ul style="list-style-type: none"> <li>• If the problem continues, notify Smiths Medical or your local Smiths Medical distributor.</li> </ul> </li> </ol>

## SECTION 9

# Testing

The HOTLINE® Warmer should be tested by hospital biomedical personnel prior to placing it in service. All testing and maintenance should be performed by competent personnel. If competent personnel are not available, contact Smiths Medical or your local Smiths Medical distributor.

If the HOTLINE® Warmer and any installed accessories do not pass any of the listed tests, discontinue use of the HOTLINE® Warmer and remove from service. Contact Smiths Medical or your local Smiths Medical distributor.

---

## WARNINGS

- If any visual indicator does not illuminate or the audible signal does not sound, do not use the Fluid Warmer. Remove the device from service immediately. Death or serious injury may occur to the patient or user if this warning is not followed.
- 

**Note:** Alarm testing requires a HOTLINE® Fluid Warming Set to be installed and that the HOTLINE® Warmer be turned ON and in the Operating mode.

## Alarm Signal Test



The Alarm Signal Test is used to confirm proper operation of the visual and audible alarm indicators.

- 1 Press and hold the Alarm Test button (a).
- 2 Observe the following:
  - The green Operating LED turns off.
  - Three red LEDs (Check Disposables, Add Solution, and Over Temperature) illuminate.
  - The audible alarm sounds and repeats approximately every two seconds.

## Over Temperature Alarm Test

The HOTLINE® Warmer should be running at an operating temperature of approximately 41°C to 42°C.



- 1 Press and hold the Over Temperature Alarm Test button (a).
- 2 Observe the following:
  - The recirculating solution Over Temperature Alarm activates at 43°C.
  - The green Operating LED turns off.
  - The red Over Temperature LED (b) illuminates.
  - The audible alarm sounds and repeats approximately every two seconds.
- 3 Stop pressing the Over Temperature Alarm Test button to stop the test.



## Add Recirculating Solution Test

The HOTLINE® Warmer is equipped with a float switch, which senses the recirculating solution level in the reservoir. When the recirculating solution is too low, the Add Recirculating Solution Alarm will activate.

- 1 Remove the fill-port plug (c) on the reservoir.
  - 2 Gently depress the float switch (d). (This action will simulate the low solution condition.)
- Note:** Use a non-metal tool to depress the float switch because the float switch contains a magnet.
- 3 Observe the following:



- The green Operating LED turns off.
- The red Add Recirculating Solution LED (e) illuminates.
- The audible alarm sounds and repeats approximately every two seconds.



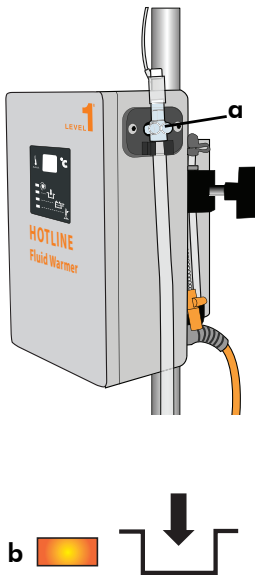

## Check Disposables Test

An interlock switch/sensor, located in the socket on the right side of the HOTLINE® Warmer, senses a properly installed HOTLINE® Fluid Warming Set. When the switch does not sense a HOTLINE® Fluid Warming Set, the Check Disposables alarm activates.

- 1 Slowly remove the HOTLINE® Fluid Warming Set (a) from the HOTLINE® Warmer socket.
- 2 Observe the following actions:
  - The green Operating LED turns off.
  - The red Check Disposables LED (b) illuminates.
  - The audible alarm sounds and repeats approximately every two seconds.

**Note:** In any alarm condition, the pump should not be running. A small amount of solution dripping from the disconnection is normal and should stop in a few seconds.

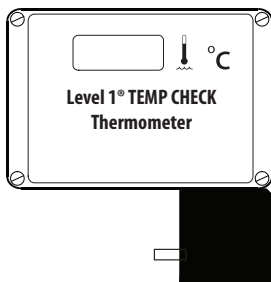

## Temperature Verification of the Recirculating Solution

Use the Level 1® TEMP CHECK Thermometer (HLTA-40) to verify the displayed recirculating solution temperature. Other methods of temperature verification may be inaccurate.

TEMP CHECK provides an accurate reading of the highest temperature of the recirculating solution. Because the temperature of the reservoir is typically 0.5°C to 2.0°C lower than the temperature from the heater, and the temperature of the recirculating solution begins to drop due to the effect of ambient temperature on the HOTLINE® Fluid Warming Set, the highest temperature of the solution is just after it leaves the heater. During the temperature verification test, the TEMP CHECK is positioned on the right side of the HOTLINE® Warmer attached to the socket and senses the solution just after it leaves the heater and before it enters the HOTLINE® Fluid Warming Set.

Refer to the TEMP CHECK HLTA-40 Thermometer Operator's Manual for complete Temperature Verification and Calibration Instructions.

---

To verify the recirculating solution temperature, you will need the following:

- TEMP CHECK (HLTA-40)
- HOTLINE® Warmer
- HOTLINE® Fluid Warming Set

To Verify the Recirculating Solution Temperature:

- 1** Plug the HOTLINE® Warmer into a power outlet.
- 2** Place the TEMP CHECK on the top right corner of the HOTLINE® Warmer and plug it into the socket on the right side of the HOTLINE® Warmer.
- 3** Plug the Twin-Tube Connector on the HOTLINE® Fluid Warming Set into the socket on the right side of the TEMP CHECK.
- 4** Remove the black label from the auxiliary outlet on the back of the HOTLINE® and plug in the TEMP CHECK power cord.

**Note:** The auxiliary outlet is for use only with Smiths Medical accessories.

- 5** Turn ON the HOTLINE® Warmer. Allow 15 minutes for the temperature to stabilize.
- 6** If the TEMP CHECK display indicates a temperature between 41°C and 42°C, and the HOTLINE® Warmer display equals the TEMP CHECK display, recirculating solution verification is complete. Refer to the TEMP CHECK Manual for OVERTEMP ALARM verification.
- 7** If the TEMP CHECK display does not indicate a temperature between 41°C and 42°C, refer to the TEMP CHECK Manual for calibration instructions.

---

## Periodic Electrical Testing

Electrical Safety Tests must be performed by competent personnel authorized by the institution to perform such testing. The Safety Tests must be performed and documented at least once per year, or according to institutional policy. These tests include but are not limited to:

- Leakage current
- Ground bond test

### Leakage Current

Leakage current must be tested according to methods and pass/fail criteria described in UL 2601-1 or EN 60601-1. Leakage current must be performed with the heater circuit in the full ON condition. To achieve this condition, perform the test when the reservoir is at room temperature. When the HOTLINE® Warmer is first turned on and the temperature is rapidly rising, but still below 41°C, the heater circuit is in a full ON condition.

Note: The HOTLINE® Warmer is equipped with sensing interlocks. A HOTLINE® Fluid Warming Set is required to correctly operate the HOTLINE® Warmer and perform leakage current testing. Do not defeat the sensing interlocks or try to operate the HOTLINE® without a HOTLINE® Fluid Warming Set in place.

### Ground Bond Test

Ground bond test must be tested according to methods and pass/fail criteria described in UL 2601-1 or EN 60601-1.

## SECTION 10

# Maintenance

Only competent personnel should perform any routine maintenance and repairs to the HOTLINE® Warmer. Maintenance is scheduled with each use, every 30 days, and every 12 months. The tasks are described below.

## Maintenance Performed with Every Use

---

### CAUTIONS

- Do not autoclave or immerse any part of the HOTLINE® Warmer in liquids, which may cause damage and improper functioning.

---

Clean and inspect the HOTLINE® Warmer.

#### Clean the Exterior

Clean the entire HOTLINE® Warmer after every use.

---

### CAUTIONS

- Never use organic solvents (e.g., acetone), strong acids, or bases to clean any portion of the HOTLINE® Warmer
- Do not place the HOTLINE® Warmer directly under a faucet or use a faucet sprayer to rinse. Never spray cleaning or other fluids into openings on the HOTLINE® Warmer or into the external connectors.

- 
- 1 Unplug the HOTLINE® Warmer before servicing.
  - 2 Visually inspect the HOTLINE® Warmer to ensure there is no visible damage or deterioration of the enclosure such as cracks, or deterioration of the labels and power cord. Do not clean if there is a defect. Contact Smiths Medical or your local Smiths Medical distributor.
  - 3 Immerse a soft cloth or sponge as an applicator into the cleaning solution consisting of mild liquid detergent soap and warm tap water mixture. Squeeze out excess solution so that the applicator is not dripping. Wipe or scrub the entire surface of the enclosure and

control panels. Use a soft brush to clean the power cord if necessary.

- 4** Rinse a separate soft cloth or sponge in room temperature running potable water. Squeeze out excess water so that the applicator is not dripping. Wipe all of the aforementioned surfaces. Repeat rinsing the cloth or sponge several times with fresh running water during this process to insure all visible residue is removed.
- 5** Dry the item with a hand towel or soft cloth.
- 6** Visually inspect the HOTLINE<sup>®</sup> Warmer and its components to insure that they have been thoroughly cleaned. Repeat cleaning procedure if necessary.
- 7** After thoroughly cleaning the HOTLINE<sup>®</sup> Warmer, perform disinfection if required.
- 8** If it is hospital policy to perform disinfection as part of reprocessing, then follow your institution's guidelines for disinfecting of the surfaces of non-critical medical devices. The list below includes low-level disinfectants that are commonly used in the medical community and high-level disinfectants that are claimed by the manufacturer. The effectiveness of these listed disinfectants should be validated using the hospital procedures.

The following disinfectant agents can be used without causing damage to the enclosure:

Low Level Disinfectants:

- fantastik<sup>®</sup> All Purpose Cleaner

High Level Disinfectants:

- 1.56% Phenol (e.g., Sporicidin<sup>®</sup>)
  - 3.4% Glutaraldehyde (e.g., CIDEX<sup>®</sup> Plus)
  - 10% Bleach solution
  - 1% Ammonia solution
  - Surface disinfectants compatible with plastic materials.
- 9** Rinsing of the disinfectant residue should be done using a soft cloth or sponge as the applicator.

### General Inspection

- Check the condition of the HOTLINE® Warmer with a visual inspection before using. Remove from service any HOTLINE® Warmer that shows physical damage.
- If the HOTLINE® Fluid Warming Set does not install easily, lubricate the O-Rings as directed in the following section.

### Disinfect the Reservoir and Change the Recirculating Solution

Disinfect the reservoir and change the recirculating solution every 30 days or every 12 months based on the recirculating solution used for the HOTLINE® Warmer. Refer to the following table for the maintenance schedule.

Recirculating Solution	Preparation	Maintenance
0.3% Hydrogen Peroxide Solution	Mix 140 ml of 3% hydrogen peroxide with 1,260 ml of distilled water.	Replace solution and disinfect reservoir every 12 months.
Distilled Water	Use distilled water.	Replace solution and disinfect reservoir every 30 days.
35% Isopropyl Alcohol Solution	Mix 700 ml of 70% isopropyl alcohol with 700 ml of distilled water.	Replace solution and disinfect reservoir every 30 days.

**Note:** Use distilled water only, not tap water. Failure to do so may cause build-up of mineral deposits in the recirculating solution path, which may impair heater performance.

### Disinfect the Reservoir

- 1 Unplug the HOTLINE® Warmer before servicing.
- 2 Remove the drain tube from the holder on the rear of the HOTLINE® Warmer.
- 3 Invert the drain tube (a) and place a container under the end of the tube. Remove the end cap (b) and drain the recirculating solution into the container.
- 4 When all the recirculating solution has drained from the reservoir, replace the end cap and insert the drain tube back in the holder.
- 5 Prepare a 0.3% hydrogen peroxide solution by mixing 140 ml of 3% hydrogen peroxide solution and 1,260 ml of distilled water.

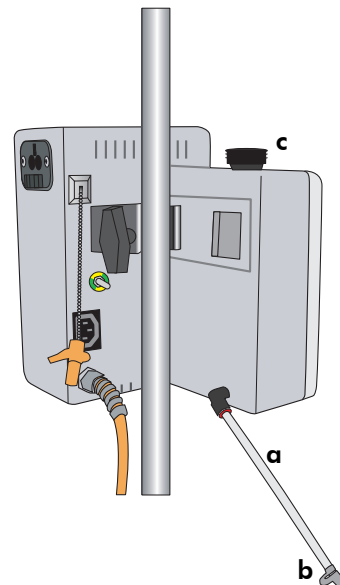

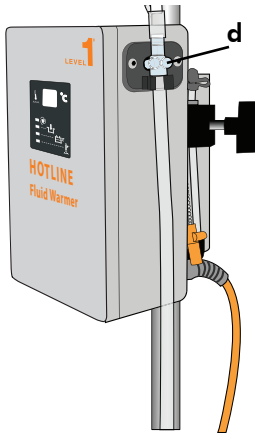

- 6 Remove the fill-port plug (c), fill the reservoir with the hydrogen peroxide solution, and replace the fill-port plug.
- 7 Remove the reflux plug from the socket if required, and insert a HOTLINE® Fluid Warming Set (d) (L-70, L-70NI, L-80) into the socket.
- 8 Turn the HOTLINE® Warmer ON, and let the recirculating solution circulate for a 30-minute disinfection period.
- 9 Turn the HOTLINE® Warmer OFF and unplug the power cord.
- 10 Empty the reservoir.
- 11 Remove the HOTLINE® Fluid Warming Set and discard according to established hospital procedures.

These suggested instructions are designed to be used in conjunction with established hospital procedures.

### Add Recirculating Solution

#### CAUTIONS

- Do not fill the HOTLINE® Warmer reservoir with a HOTLINE® Fluid Warming Set or a TEMP CHECK in place. Failure to remove the HOTLINE® Fluid Warming Set before the fill procedure may result in an air lock in the HOTLINE® Warmer.

- 1 Prepare the recirculating solution.
- 2 Remove the fill-port plug.
- 3 Fill the reservoir with 1.4 liters of recirculating solution.
- 4 Replace the fill-port plug.

### Maintenance Performed Every 30 Days

#### Disinfect the Reservoir and Change Recirculating Solution for Distilled Water and 35% Isopropyl Alcohol Solution

Refer to *Disinfect the Reservoir and Change the Recirculating Solution* procedure in this section.

### Lubricate O-Ring Seals

- 1 Place a small amount of silicone lubricant on a cotton swab.
- 2 Apply silicone lubricant along the O-Rings inside the socket (a) located on the right side of the HOTLINE® Warmer.

Silicone lubricant is available from Smiths Medical, (Silicone lubricant P/N 80-04-002).

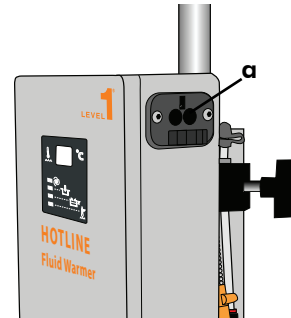

### Maintenance Performed Every 12 Months

#### Disinfect the Reservoir and Change Recirculating Solution for 0.3% Hydrogen Peroxide Solution

Refer to *Disinfect the Reservoir and Change the Recirculating Solution* procedure in this section.

#### Replace O-Rings (O-Ring Kit: P/N 80-04-001)

- 1 Unplug the HOTLINE® Warmer before servicing.
- 2 Remove the socket head screws (b) with a 0.31cm (1/8") hex wrench.
- 3 Remove the face plate, being careful not to damage the micro-switch lever.
- 4 Remove the old O-rings and clean the sockets with a cotton swab.
- 5 Apply silicone lubricant to two new O-rings and install into the sockets.
- 6 Reassemble in reverse order, being careful not to damage the micro-switch lever.
- 7 Insert HOTLINE® Fluid Warming Set and power on HOTLINE® Warmer to verify that there are no leaks around the face plate.

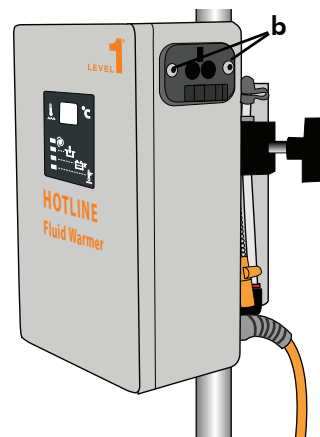

### Testing HOTLINE® Warmer Operation

Perform all the tests described in the testing section of this manual. See Section 9, *Testing*. The Scheduled Maintenance Checklist below also lists the tests.

### Maintenance Log

All maintenance and testing should be done by competent personnel. Regularly scheduled maintenance ensures proper functioning of the equipment. Refer to the table below for required tasks and frequency of routine maintenance.

### Maintenance Checklist

Task	Every Use	Every 30 Days	Every 12 Months
Clean the Exterior	<input type="checkbox"/>		
General Inspection	<input type="checkbox"/>		
Disinfect the Reservoir and Change Distilled Water or Isopropyl Alcohol solution		<input type="checkbox"/>	
Lubricate the O-Rings		<input type="checkbox"/>	
Disinfect the Reservoir and Change the Hydrogen Peroxide Solution			<input type="checkbox"/>
Replace the O-Rings			<input type="checkbox"/>
Alarm Signal Test			<input type="checkbox"/>
Add Recirculating Solution Test			<input type="checkbox"/>
Check Disposables Test			<input type="checkbox"/>
Over Temperature Alarm Test			<input type="checkbox"/>
Verify Temperature Calibration			<input type="checkbox"/>
Electrical Safety Tests			<input type="checkbox"/>

## SECTION 11

## Limited Warranty

Smiths Medical ASD, Inc. (the “Manufacturer”) warrants to the Original Purchaser that the HOTLINE® Blood and Fluid Warmer (the “HOTLINE® Warmer”), not including accessories, shall be free from defects in materials and workmanship under normal use, if used in accordance with this Operator’s Manual, for a period of one year from the actual date of sale to the Original Purchaser. THERE ARE NO OTHER WARRANTIES.

This warranty does not cover normal wear and tear and maintenance items, and excludes any accessory items or equipment used with the HOTLINE® Warmer.

Subject to the conditions of and upon compliance with this Limited Warranty, the Manufacturer will repair or replace at its option without charge (except for a minimal charge for postage and handling) any HOTLINE® Warmer (not including accessories) which is defective if a claim is made during such one-year period.

The following conditions, procedures, and limitations apply to the Manufacturer's obligation under this warranty:

- A. **Parties Covered by this Warranty:** This warranty extends only to the Original Purchaser of the HOTLINE® Warmer. This warranty does not extend to subsequent purchasers. The Original Purchaser may be medical personnel, a hospital, or institution which purchases HOTLINE® Warmers for treatment of patients. The Original Purchaser should retain the invoice or sales receipt as proof as to the actual date of purchase.
- B. **Warranty Performance Procedure:** Notice of the claimed defect must be made in writing or by telephone to the Manufacturer as follows: Customer Service Department, Smiths Medical ASD, Inc., 160 Weymouth Street, Rockland, MA 02370, (800) 258-5361. Notice to the Manufacturer must include date of purchase, model and serial number, and a description of the claimed defect in sufficient detail to allow the Manufacturer to determine and facilitate any repairs which may be necessary. AUTHORIZATION MUST BE OBTAINED PRIOR TO RETURNING THE HOTLINE® WARMER. If authorized, the HOTLINE® Warmer must be properly and carefully

---

packaged and returned to the Manufacturer, postage prepaid. Any loss or damage during shipment is at the risk of the sender.

**C. Conditions of Warranty:** The warranty is void if the HOTLINE® Warmer has been 1) repaired by someone other than the Manufacturer or its authorized agent; 2) altered so that its stability or reliability is affected; 3) misused; or 4) damaged by negligence or accident. Misuse includes, but is not limited to, use not in compliance with the Operator's Manual or use with non-approved accessories. Removal or damage to the HOTLINE® Warmer's serial number will invalidate this warranty.

**D. Limitations and Exclusions:** Repair or replacement of the HOTLINE® Warmer or any component part thereof is the EXCLUSIVE remedy offered by the Manufacturer. The following exclusions and limitations shall apply:

1. No agent, representative, or employee of the Manufacturer has authority to bind the Manufacturer to any representation or warranty, expressed or implied.
2. THERE IS NO WARRANTY OF MERCHANTABILITY OR FITNESS OR USE OF THE HOTLINE® WARMER FOR ANY PARTICULAR PURPOSE.
3. The HOTLINE® Warmer can only be used under the supervision of medical personnel whose skill and judgment determine the suitability of the HOTLINE® Warmer for any particular medical treatment.
4. All recommendations, information, and descriptive literature supplied by the Manufacturer or its agents are believed to be accurate and reliable, but do not constitute warranties.

The Manufacturer disclaims responsibility for the suitability of the HOTLINE® Warmer for any particular medical treatment or for any medical complications resulting from the use of the HOTLINE® Warmer. The Manufacturer shall not be responsible for any incidental damages or consequential damages to property, loss of profits, or loss of use caused by any defect or malfunction of the HOTLINE® Warmer.

This warranty gives the Original Purchaser specific legal rights, and the Original Purchaser may have other legal rights which may vary from state to state.

## SECTION 12

# Service

---

## WARNINGS

- **No user-serviceable parts. All service must be performed by Smiths Medical or competent personnel. Death or serious injury may occur if this warning is not followed.**

---

All service must be performed by Smiths Medical or competent personnel. Service by any other person or organization voids the warranty and transfers liability for malfunctions of the device to the servicing organization.

## Non-Warranty Work

Devices received that are no longer under warranty can be returned for repair at a cost. The device will be promptly inspected and a verbal estimate of the repair cost will be provided. A purchase order will be required from the original purchaser consistent with the verbal estimate. A written estimate will be provided upon request.

Before returning the HOTLINE<sup>®</sup> Warmer for service, contact Smiths Medical for Returned Goods Authorization. Be sure that ALL recirculating solution is drained from the device before packing the HOTLINE<sup>®</sup> Warmer for shipment.

Note: The HOTLINE<sup>®</sup> Warmer must be cleaned and disinfected for repair shipment or it will be immediately returned as received.

## Additional Documentation

Upon request Smiths Medical will provide the following documentation:

- Circuit diagrams
- Components parts list(s)
- Description of function
- Service and calibration instructions

---

## Disposal Information

Observe national and local codes or requirements for disposal of contaminated materials and for recycling of solid waste materials that may impact the environment.

## Service Contacts

Contact your Smiths Medical Technical Service Department or Smiths Medical distributor at:

### USA/Canada

Smiths Medical ASD, Inc.  
160 Weymouth Street  
Rockland, MA 02370 USA  
USA/Canada 1-800-258-5361  
International +1-781-878-8011

### European Representative

Smiths Medical International Ltd.  
Colonial Way  
Watford, Herts, WD24 4LG, UK  
Tel +44 (0) 1923 246434  
Fax +44 (0) 1923 240273

### Australian Representative

Smiths Medical Australasia Pty. Ltd.  
61 Brandl Street,  
Eight Mile Plains, QLD 4113, Australia  
Tel +61 (0) 7 3340 1300  
Fax +61 (0) 7 3340 1399

### New Zealand

Tel 0 800 444 200

[www.smiths-medical.com](http://www.smiths-medical.com)

## SECTION 13

# Specifications and Accessories

## System Specifications

Standard Compliance	Guidelines	
Product Safety	EN 60601-1, UL 2601-1	
EMC	EN 60601-1-2, FCC 47 CFR Part 15, Class B	
Enclosure Protection	IEC 60529 IP Code: IPX1	
Fluid Warmers	ASTM F2172-02	
Physical	Dimensions	
Height, Overall	24.1 cm	(9.5 inches)
Width, Overall	21.0 cm	(8.3 inches)
Depth, Overall	17.8 cm	(7.0 inches)
Weight, Dry	3.5 Kg	(7.6 lbs)
Weight, Wet (with recirculating solution)	5.0 Kg	(11.0 lbs)
Weight, Shipping	3.6 Kg	(7.95 lbs)
Recirculating Solution Capacity	1.4 L	(0.37 gallons)
Maximum Height on I.V. Pole	107 cm	(42 inches)
Environmental	Temperature	Humidity [%]
Operation	10°C to 45°C	10 to 95
Transportation	-18°C to 60°C	5 to 90
Storage	-18°C to 60°C	5 to 90
Thermal	Temperature	
Temperature Set Point	41.9°C ± 0.1°C	
Over Temperature Set Point	43.1°C	
Electrical	Type	
MAINS Power Input:		
100V	100VAC, 50/60 Hz, 3.8 Amps	
115V	115VAC, 50/60 Hz, 3.0 Amps	
230V	230VAC, 50/60 Hz, 1.5 Amps	
MAINS Auxiliary Supply Power Output:		
100V	100VAC, 50/60 Hz, 1.0 Amps	
115V	115VAC, 50/60 Hz, 1.0 Amps	
230V	230VAC, 50/60 Hz, 0.6 Amps	

Electrical	Type
Protection Against Electrical Shock	Class 1 Equipment, Type BF
Mode of Operation	Continuous
Type of Current	Alternating
Ingress Protection Rating	IPX1
Performance	
Recirculating Solution Temperature	Recirculating solution temperature reaches 37°C from ambient in about 4 minutes
Normothermic Flow Rates	At gravity flow rates to 5,000 ml per hour

The HOTLINE® Warmer is manufactured to be in compliance with UL 2601-1 (HL-90 115V) and EN 60601-1 (HL-90 230V).

### Electromagnetic Compliance

HOTLINE® Warmer is certified to be in compliance with the European Communities Council Directive relating to Electromagnetic Compatibility (EMC): (89/336/EEC). Test methods and acceptance criteria as specified in EN 60601-1-2 demonstrate conformance.

## Electromagnetic Environmental Recommendations











Recommended separation distances between portable and mobile RF communications equipment and the HOTLINE® Warmer			
The HOTLINE® Warmer is intended for use in an electromagnetic environment in which radiated RF disturbances are controlled. The customer or the user of the HOTLINE® Warmer can help prevent electromagnetic interference by maintaining a minimum distance between portable and mobile RF communications equipment (transmitters) and the HOTLINE® Warmer as recommended below, according to the maximum output power of the communications equipment.			
Rated maximum output power of transmitter W	Separation distance according to frequency of transmitter m		
	150 kHz to 80 MHz $d=[3.5/\sqrt{P}]$	80 MHz to 800 MHz $d=[3.5/E1] \sqrt{P}$	800 MHz to 2.5 GHz $d=[7/E1] \sqrt{P}$
0.01	0.116	0.116	0.233
0.1	0.368	0.368	0.737
1	1.16	1.16	2.33
10	3.69	3.69	7.38
100	11.66	11.66	23.33
For transmitters rated at a maximum output power not listed above, the recommended separation distance d in metres (m) can be estimated using the equation applicable to the frequency of the transmitter, where P is the maximum output power rating of the transmitter in watts (W) according to the transmitter manufacturer.			
NOTE 1 At 80 MHz and 800 MHz, the separation distance for the higher frequency range applies.			
NOTE 2 These guidelines may not apply in all situations. Electromagnetic propagation is affected by absorption and reflection from structures, objects and people.			



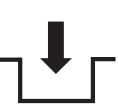











## Accessories















REF	Product Description
L-70	HOTLINE® Fluid Warming Set with Injection Port
L-70NI	HOTLINE® Fluid Warming Set without Injection Port
L-80	HOTLINE® Warming Set with L-10 Gas Vent
L-10	Gas Vent
PC-8	T-Connector, 20.3 cm (8") Patient Lead with Injection Port
YC-8	Y-Connector, 20.3 cm (8") Patient Lead with Injection Port

## SECTION 14

## Symbols

Symbols	Definitions
	Power switch in the ON position
	Power switch in the OFF position.
	ON/Operation
	Reservoir Temperature Display
	Add Recirculating Solution
	Check Disposables
	Over Temperature
	Maximum Reservoir Level
	Minimum Reservoir Level
	Alarm Test
	Type BF Equipment

Symbols	Definitions
	<b>Warning:</b> Do not stick HOTLINE® tubing with needles. Patient injury or death could result.
<b>IPX1</b>	Protected Against Dripping Water
	Catalog Number
	Serial Number
	Part Number
	Batch Code
	Authorized Representative in the European Community
	Manufacturer
	Date of Manufacture
	Quantity
	Protective Earth [Ground]
	Alternating Current
	Do Not Reuse
	Consult instructions for use
	<b>Caution</b>
	Electric Shock Hazard

Symbols	Definitions
	Latex Free
	<b>Caution:</b> This product contains natural rubber latex which may cause allergic reactions.
<b>Rx ONLY</b>	<b>Caution:</b> Federal (U.S.A.) law restricts this device to sale by or on the order of a physician.
<b>CLASS 1</b>	Device is class type 1 equipment
	Protective earth terminal
	Do not use if package is damaged.
	Sterile fluid path, ethylene oxide gas sterilized
	Temperature Limitation
	Humidity Limitation
	Use by
	Keep away from sunlight
	Keep dry
	Recyclable Product
	Device has been tested by National Technical Systems, a nationally recognized technical laboratory, to meet U.S. requirements for safety.
	Collect separately for electrical and electronic equipment.
	CE Mark and Notified Body number (0473 indicates AMTAC)
	Contains or Presence of Phthalate: bis(2-ethylhexyl) phthalate (DEHP)

## Numerics

- 0.3% Hydrogen peroxide solution
  - maintenance schedule 30
  - preparation 11, 30
- 35% Isopropyl alcohol solution
  - maintenance schedule 30
  - preparation 11, 30

## A

- Accessories list 40
- Add Recirculating Solution mode 16
- Add Recirculating Solution test 24
- Add Solution LED 16
- Additional documentation 36
- After Use 20
- Alarm signal test 23
- Alarm Test button 14
- Alcohol (isopropyl) solution 11, 30
- Anesthetic use warning 7
- Assembly instructions 9
- Australian representative 37
- Auxiliary electrical outlet 3

## B

- Biohazardous material
  - disposal information 20

## C

- Canada service contact 37
- Cautions 8
  - L-10 Gas Vent 8
- Change the recirculating solution 30
- Check Disposables LED 15
- Check Disposables mode 15
- Check Disposables Test 25
- Clamp for I.V. pole 3
- Clean exterior surfaces 28
- Components 2
  - description 2
- Connect the intravenous administration set 19
- Contents
  - list 9
- Contraindications 5
- Controls 13
- Conventions used in manual 1

## D

- Description
  - components 2
    - HOTLINE Fluid Warming Sets 4
    - HOTLINE Warmer 2
- Disinfect the reservoir 10, 30
- Display Panel 2, 13
  - description 13
- Disposal information 37
  - biohazardous materials 20
  - electrical device 37
- Distilled water
  - maintenance schedule 30
- Drain tube 3

## E

- Electrical safety tests 11, 27
- Electrical specifications 38
- Electromagnetic compliance 39
- Electromagnetic environmental recommendations 40
- Environmental specifications 38
- European representative 37

## F

- Fill-port plug 3
- Float switch 3

## G

- Grounding reliability 7, 17
- Guidelines for safe use 5

## H

- HOTLINE Fluid Warming Sets
  - description 4
  - priming volume 4
- Hydrogen peroxide solution
  - preparation 10, 11, 30

## I

- I.V. pole mounting height restrictions 9
- Important safety information 5
- Indications for use 1
- Infusate delivery temperatures 12

Intravenous administration set  
 connect 19  
 Isopropyl alcohol solution 11, 30

## L

L-10 Gas Vent  
 warnings and cautions 8  
 LCD 13  
 LEDs 13  
 Light-emitting diodes (LEDs) 13  
 Liquid crystal display (LCD) 13

## M

Maintenance 28  
 performed every 12 months 32  
 performed every 30 days 32  
 performed with every use 28  
 Maintenance schedule  
 recirculating solution 11, 30  
 Modes of operation 15  
 Mounting to I.V. pole 9

## N

Non-Warranty work 36

## O

OFF mode 15  
 ON/Operating mode 15  
 Operating LED 15  
 Operation modes 13, 15  
 O-Rings  
 lubricate seals 32  
 replace 32  
 Over Temperature Alarm mode 16  
 Over Temperature LED 16  
 Over Temperature test 24  
 Over Temperature Test button 14

## P

Performance specifications 39  
 Physical specifications 38  
 Power and Alarm Test Panel 14  
 Power cord 3  
 Power ON/OFF switch 14  
 priming volume  
 HOTLINE Fluid Warming Sets 4

Principle of operation 12

## R

Recirculating solution  
 change 30  
 maintenance schedule 11, 30  
 preparation 11, 30  
 protocols 11  
 Reflux plug 3  
 Replace  
 O-Rings 32  
 Reservoir 3  
 fill with recirculating solution 11  
 Reservoir level display 14

## S

Service 36  
 Service contacts 37  
 Set Up the HOTLINE Fluid Warming Set 17  
 Set Up the HOTLINE Warmer 17  
 Socket 2  
 Specifications 38  
 electrical 38  
 environmental 38  
 performance 39  
 physical 38  
 thermal 38  
 Standard compliance guidelines 38  
 Storage 20  
 Symbols 41  
 System specifications 38

## T

Temperature  
 display 13  
 Over Temperature Alarm 16  
 Temperature verification of the recirculating  
 solution 25  
 Testing 23  
 Thermal specifications 38  
 Troubleshooting 21  
 Add Recirculating Solution alarm 21  
 Check Disposables alarm 21  
 electrical interference 22  
 hot cabinet 22  
 install HOTLINE Fluid Warming Set 22

no power 21  
Over Temperature alarm 21  
recirculating solution leaks 22

## **U**

USA service contact 37  
Using the HOTLINE Warmer 19

## **W**

Warnings 5  
    L-10 Gas Vent 8  
Warranty 34