

Bivona® Customized FlexTend™ Tracheostomy Tube Template

PORTEX™ NEW easy-to-read template
Just follow steps 1-9. Please specify:

smiths medical
bringing technology to life

PHONE: 1 800 424 8662 FAX: 219 989 7435
WEB: www.smiths-medical.com



1. Shaft Length:

- 1a: Shaft Length _____ mm (5mm min; 60mm max)
 1b: Shaft Length _____ mm (30mm min; 140mm max.)

2. Shaft:



- Shaft: I.D. _____ mm (2.5-9.5mm) or Shaft: O.D. _____ mm

3. Connector:

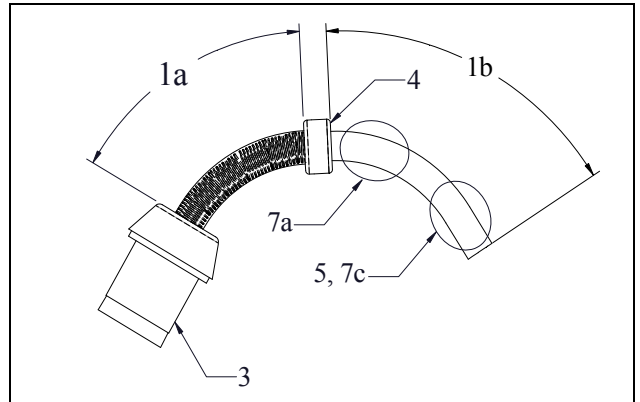
<input type="checkbox"/> 3a. Swivel 2.5-9.5mm 	<input type="checkbox"/> 3b. Fixed 2.5-6.0mm 
--	---

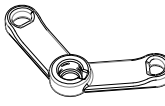
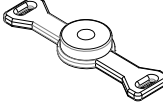
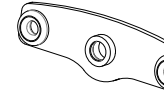

4. Neck Flange:

<input type="checkbox"/> 4a. 2.5-6.0mm  Neck Flange Length: 60mm	<input type="checkbox"/> 4c. 5.0-9.5mm  Neck Flange Length: 83mm	<input type="checkbox"/> 4d. 6.5-9.5mm  Neck Flange Length: 67mm	<input type="checkbox"/> 4e. 2.5-4.0mm  Neck Flange Length: 47mm	<input type="checkbox"/> 4f. 2.5-6.0mm  Neck Flange Length: 60mm
---	---	---	---	---

5. Cuff:

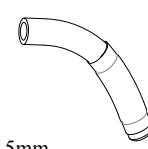
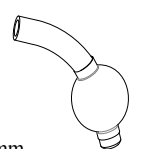
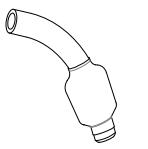
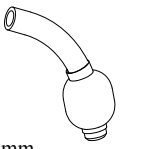
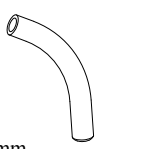
<input type="checkbox"/> 5a. TTS™ Tight to Shaft  2.5-9.5mm	<input type="checkbox"/> 5b. Aire-Cuf® Pedi  2.5-5.5mm	<input type="checkbox"/> 5b. Aire-Cuf® Adult  5.0-9.5mm	<input type="checkbox"/> 5c. Fome-Cuf®  2.5-9.5mm	<input type="checkbox"/> 5d. Cuffless  2.5-9.5mm
--	---	--	--	---

6. Specialty Shaft:

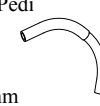
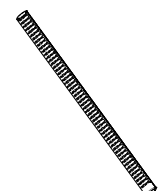
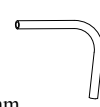
<input type="checkbox"/> 6a. Std. Curved <input type="checkbox"/> Neo / Pedi  2.5-6.0mm	<input type="checkbox"/> 6b. Hyperflex Reinforced – Straight  2.5-9.5mm
<input type="checkbox"/> Adult  5.0-9.5mm	

7. Optional:

<input type="checkbox"/> 7a. Proximal (TOP) Cuff <input type="checkbox"/> TTS™ Cuff <input type="checkbox"/> Aire-Cuf® <input type="checkbox"/> Fome-Cuf® <input type="checkbox"/> Pediatric <input type="checkbox"/> Adult Cuff position from Neck Flange _____ mm	<input type="checkbox"/> 7b. Stoma seal <input type="checkbox"/> Solid Silicone ____ mm OD ____ mm Length <input type="checkbox"/> Tapered <input type="checkbox"/> Non Tapered	<input type="checkbox"/> 7c. Distal (BOTTOM) Cuff <input type="checkbox"/> Cuff distance from tip of shaft _____ mm Note: Cuff distance from tip cannot be less than the minimum standard distance listed below: a. Pediatric TTS, Aire & Fome – 3mm b. Adult Aire & Fome – 5mm c. Adult TTS – 9mm
		<input type="checkbox"/> 7d. Talk Attachment NOTE: 5.0mm I.D. Adult shaft or above only.

8. Approval: NOTE: Please print clearly. Smiths Medical will review the completed template for compliance. Any required modifications will be made with the approval of a clinician.

HOSPITAL/CLINIC

DATE

P.O. NUMBER

CLINICIAN SIGNATURE/CREDENTIALS

PATIENT/CLIENT ID

(Smiths Medical Use Only) Approval: _____ Reorder: _____

9. Select Type of Service:

- 3-4 weeks (Sterile) Standard Service (NON-Sterile) Express Service (NON-Sterile) Same Day Service (NON-Sterile) – USA Only

Caution: Federal (USA) law restricts this device to sale by or on the order of a physician.

The Smiths Medical and Portex design marks; Bivona, FlexTend, TTS, Aire-Cuf, and Fome-Cuf are trademarks of the Smiths Medical family of companies. The Symbol ® indicates the trademark is registered in the U.S. Patent and Trademark Office and certain other countries. © 2012 Smiths Medical family of companies. All rights reserved.